

GS-VBM480-DH

Vertical Stitch Border Machine

High-volume border production from Gateway Systems.
Create stylish, Engineered Borders™ with this single-lane border-quilting machine.

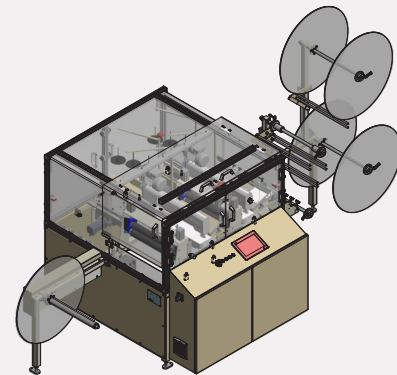
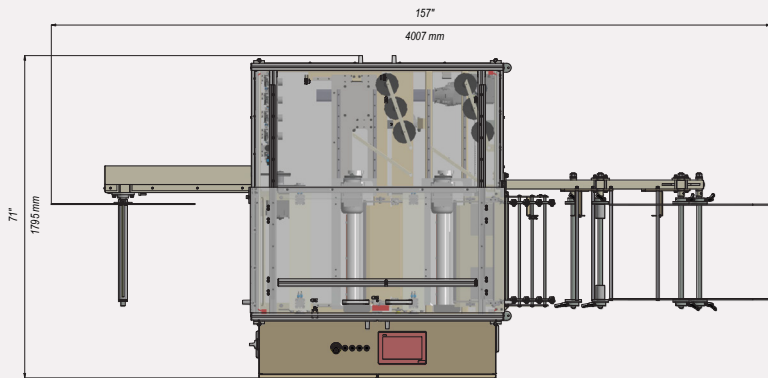
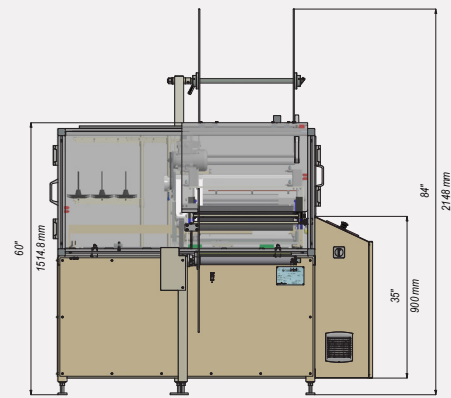
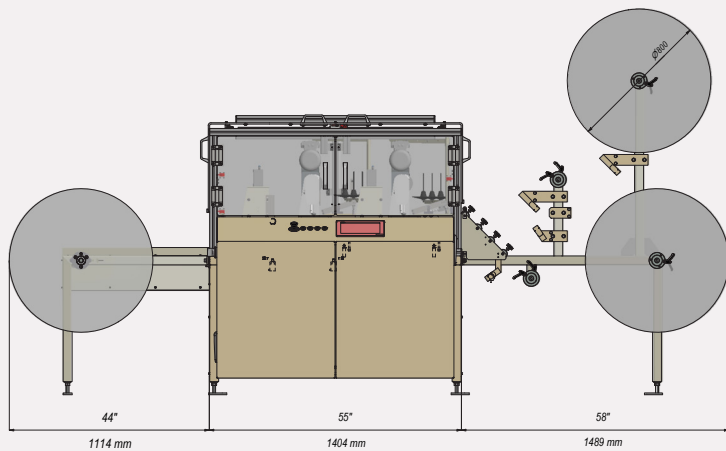

SPECIFICATIONS	GS-VBM480-DH
Speed – max rpm	3000SPM
Maximum finished material width	18" (480mm)
Minimum finished material width	4.75" (125mm)
Maximum material thickness	1.2" (30mm) foam or 10.5 oz (300gm) of polyester
Stitch length	4-10 spi (2.5-6.5mm)
Recommended stitch length	7 spi (3.5mm)
Needle size	System UY 128 GAS size 150
Air pressure (psi/bar)	90 psi (6bar)
Air consumption (CFM)	0.5 cfm
Current (amps)	12 amps
Voltage	380 volts 3ph 50Hz
CE approved	yes
Machine weight	830kg/1,830 lbs

The GS-VBM480-DH is a high-performance vertical stitch border machine built of sturdy construction for dependable, high-speed production.

- Vertical stitch border quilter with (2) Pfaff high-speed double-lock chainstitch sewing heads.
- Accepts border widths 150mm (6") - 505mm (19.5").
- Creates sewn vertical lines or V-shaped patterns.
- Efka needle positioner motors.
- Fully integrated material rewind, top, and bottom-thread break detectors.
- Smooth sewing-head movement and material infeed dispenser for quick-and-easy material loading.
- High-quality oil-free pneumatic system.

Global Systems Group® (GSG) is a collection of the world's leading mattress machinery companies. These GSG machinery companies represent leading-edge technology in computerized quilting machines and panel cutters, automated and conventional sewing machines, and mattress-packaging equipment.

800-343-8138 • 417-237-6254 • GSGcompanies.com



GLOBAL SYSTEMS GROUP
A DIVISION OF LEGGETT & PLATT
131 Zapletal Way
Carthage, MO 64836 USA